



Design, Development and Evaluation of Neem (*Azadirachta indica*) Fruit Picker Cum Collector

M. Gowtham ^{a++}, B. Suthakar ^{b#*}, A. Surendrakumar ^{a†},
R. Kavitha ^{a‡} and P. Masilamani ^c

^a Department of Farm Machinery and Power Engineering, Agricultural Engineering College and Research Institute, Tamil Nadu Agricultural University, Coimbatore – 641 003, India.

^b Department of Farm Machinery and Power Engineering, Agricultural Engineering College and Research Institute, Tamil Nadu Agricultural University, Kumulur – 621 712, India.

^c Sugarcane Research Station, Sirugamani, Trichy – 639 115, India.

Authors' contributions

This work was carried out in collaboration among all authors. All authors read and approved the final manuscript.

Article Information

DOI: 10.9734/JEAI/2024/v46i22307

Open Peer Review History:

This journal follows the Advanced Open Peer Review policy. Identity of the Reviewers, Editor(s) and additional Reviewers, peer review comments, different versions of the manuscript, comments of the editors, etc are available here: <https://www.sdiarticle5.com/review-history/112842>

Received: 26/11/2023

Accepted: 29/01/2024

Published: 31/01/2024

Original Research Article

ABSTRACT

Harvesting of neem fruits can be done either by ground picking, shaking off the tree, or directly stripping from the branches. Since the manual collection of neem fruits is a labor-intensive process, consuming around 30 per cent of harvesting time, a simple mechanical system for picking and collecting the neem fruits from the ground was developed based on the fruit geometry and other major physical properties of neem fruits. It was observed that the moisture content of 81.95%, axial

⁺⁺ Research scholar;

[#] Associate Professor;

[†] Professor;

[‡] Professor and Head;

*Corresponding author: E-mail: suthakar@tnau.ac.in;

dimensions viz. 15.57 mm length, 9.25 mm width and 8.87 mm thickness of the fruits, 14.07 mm as geometric mean diameter, as 352 g. cm⁻¹ bulk density and 290.88 g as the weight of hundred neem fruits. The developed prototype consists of picker assembly, ejector assembly, collector assembly, connector frame, handle and traction wheel. The proposed innovation enables an eco – friendly operation of neem fruit collection without using any form of non- renewable energy sources. The developed prototype achieved a collection capacity of about 48 kg h⁻¹ which is 79.1% higher when compared with existing pneumatic ground collection system for neem fruits and 97.3% higher than the conventional method of neem fruit collection.

Keywords: *Neem harvesting; physical properties of neem; picker cum collector; ground collection system for neem fruits; picking and collection efficiency.*

1. INTRODUCTION

Neem (*Azadirachta indica*) otherwise known as A. Juss.; syn. *Melia azadirachta* L. and *Melia indica* (A.Juss.) is a tropical evergreen tree and deciduous in drier areas which is native to the Indian sub-continent [1]. The life span of this tree is more than 200 years, and it can grow on soils of almost all kinds and in adverse climatic conditions except long lasting cold and freezing conditions [2]. It can be propagated easily by seed, or 9 to 12 month-old neem seedlings can also be transplanted [3]. Neem is commonly used as traditional Indian medicine for household remedy against various human diseases [4]. Neem seed is an important source of non-edible vegetable oil and bio-pesticide compounds and contains number of limonoids such as Azadirachtin, Nimbin, Salanin and Meliantriol [5]. Azadirachtin is the most important limonoids which is having a structure similar to the insect hormone called ecdysones. It reduces insect feeding and acts as a repellent [6]. The yield of neem oil extracted from seed and kernel are about 20–25% and 40 –50%, respectively [7]. Neem tree has its native in dry forest areas of India, Pakistan, Sri Lanka, Malaysia, Indonesia, Thailand, Myanmar and Africa. Among these countries, India is the leading producer of Neem in the world by producing 4.4 lakh tonnes of neem yielding 88,440 tonnes of oil and 3.5 lakh tonnes of cake annually [8]. In Tamil Nadu, Virudhunagar and Thoothukudi districts stands in the first and second position in neem plantation with 643 ha and 427 ha of cultivation area respectively [9].

The flowering season of the neem varies by location. It usually blooms from January to May and the fruits ripen from May to August. After 3-5 years, a neem tree will begin to bear fruits. It will be fully operational in about ten years. It can produce up to 50 kg of fruits per year after the tenth year [10]. The harvesting of neem fruits can

be done either by ground picking, shaking off the tree or directly stripping from the branches. The conventional method of harvesting neem fruits includes the collection of ground fallen fruits by using hand and put together into bucket, plastic bag or gunny bag normally by female labourers [8]. In some areas, farmers lay a polythene sheet or tarpaulin sheet under the tree canopy. When the wind blows, the ripened fruits along with leaves and twigs fall on the sheet and the fruits were separated and collected in gunny bags [11]. Collection of neem fruits from the ground takes almost 30 per cent of harvesting time [12]. Manual ground collection of neem fruit is a time-consuming and laborious process. A woman labour can collect up to 10 – 15 kg per day at the wages of Rs.250 per day. As the cost of collection of neem fruits from the ground (Rs.30 kg⁻¹) exceeds the selling price of neem fruits (Rs.25 kg⁻¹). Hence, it becomes unprofitable to pick the neem fruits off the ground by manual method [9].

As of now, there is no mechanical system available for collecting neem fruits from the ground. However, Tripathi (2022) has developed a ground collection system for neem fruit based on the principle of suction. But, the developed ground collection system does not work satisfactorily due to minimal width of coverage (20 cm) and the lower suction capacity of the machine because of the uneven density of ground fallen neem fruits and the consumption of the petrol fuel for the engine also increases the cost of operation. Hence, a simple mechanical system for picking and collecting the neem fruits from the ground was developed.

2. MATERIALS AND METHODS

2.1 Conceptual Framework

The conventional method of manual ground collection of the neem fruits is being practiced by

most of the Indian farmers. The ground fallen fruits are hand-picked, separated, cleaned and finally bagged which is laborious and consumes operation. With the aim of replacing the manual picking of neem fruits, this machine was developed by studying the existing designs of fruit picking and collecting machines from different countries all over the world. The functional requirements of the mechanical type neem fruit picker cum collector are listed below,

Functional requirements:

- a) **Picking** - Neem fruits has to be picked up from the ground.
- b) **Conveying** - Picked neem fruits has to be conveyed to the collection unit.
- c) **Ejection** - Fruits which are conveyed has to be removed from the roller.
- d) **Collection**- The ejected fruits has to be collected in a collection box without any foreign materials such as leaves, twigs, stones, etc.

The conceptual drawing of the prototype mechanical type neem fruit picker is shown in Fig. 1.

2.2 Physical Properties of Neem Fruit

The picking and collection of neem fruits from the ground were greatly influenced by the physical properties of neem fruits. Hence, the physical properties that are required for development of the mechanical type neem fruit picker cum collector

such as moisture content of neem fruit, axial dimensions (length, width and thickness of the fruits), geometric mean diameter, bulk density and weight of hundred neem fruits were studied and calculated [13].

2.2.1 Moisture content

A known weight of random samples were measured using weighing balance with the sensitivity of 0.001g. These samples were kept in a hot air oven at 105°C for 24 hours. By using this oven dry method, the average moisture content of neem fruit was calculated on wet basis using the equation 1 [14]. Measurement of moisture content using hot air oven is shown in Fig. 2.

$$M.C \text{ (wet basis)} = \frac{W_1}{W_2} \times 100 \text{ (\%)} \quad (1)$$

where, W_1 = Mass of the sample after drying (g);
 W_2 = Mass of the sample before drying (g)

2.2.2 Axial dimension of the fruit

One hundred fruits were randomly selected from a bulk sample and three major perpendicular dimensions viz. Length (Fig. 3a), Width (Fig. 3b) and Thickness of the neem fruits (Fig. 3c) were measured for each fruit using a digital Vernier caliper with an accuracy of ± 0.01 mm. The geometric mean diameter was calculated from the equation 2 [13].

$$D_g = LWT^{1/3} \quad (2)$$

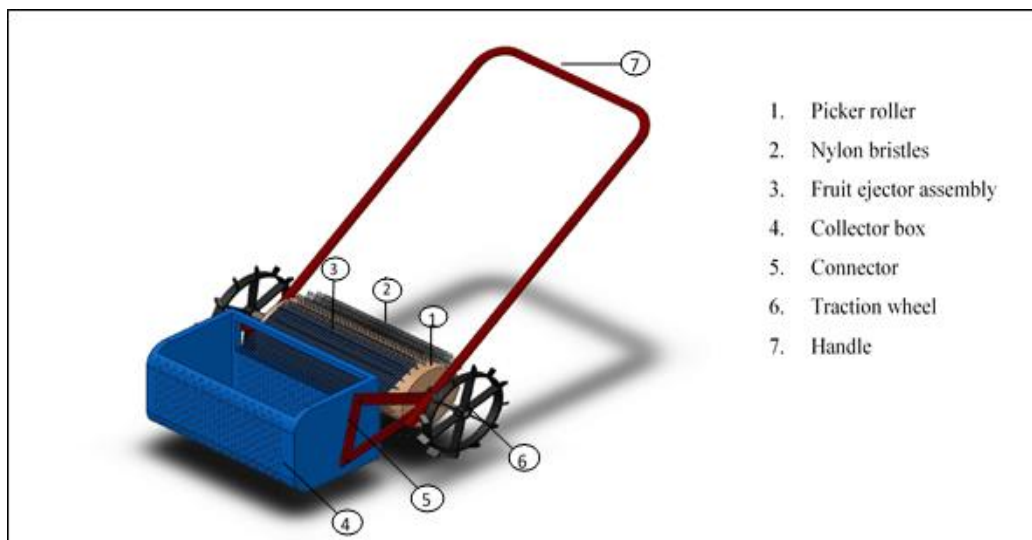

Fig. 1. Conceptual drawing of the mechanical type neem fruit picker cum collector



Fig. 2. Measurement of moisture content of neem fruits using hot air oven



Fig. 3a



Fig. 3b



Fig. 3c

Fig. 3a., 3b., 3c. Measurement of Length, Width and Thickness of neem fruit

where, D_g = Geometric mean diameter, mm; L = Length of the neem fruit, mm; W = Width of the neem fruit, mm; T = Thickness of the neem fruit, mm.

2.2.3 Thousand – unit mass

One hundred neem fruits were counted and were weighed using digital weighing balance with a least count of 0.001 g as shown in Fig. 4 and it was repeated ten times using random samples to obtain an average value of weight. Then the average weight was multiplied by ten [15].



Fig. 4. Measuring the weight of 100 neem fruits using Digital weighing balance

2.2.4 Bulk density

For determination of bulk density, Neem fruits were filled in a cylindrical container without any

compaction. Weight of the samples was measured using digital weighing balance with the least count of 0.001 g and the volume of container was also determined. The bulk density of neem fruit was calculated from the equation 3 [15].

$$BD = \frac{x}{y} \quad (3)$$

where, BD = Bulk density, kg m^{-3} ; x = Weight of the sample, kg; y = Volume of the container, m^3 .

2.3 Design of PROTOTYPE

The design requirements for the machine were compiled using the results of multiple research as well as the evaluation of other commercially available picking and collecting devices.

2.3.1 Picking assembly

The picker assembly consists of a cylindrical fruit picker roller with nylon bristles to pick neem fruits from the ground. The bristles trap the fruits as the roller rotates, and then the fruits are conveyed to the collector assembly.

2.3.2 Collection assembly

Collector assembly consists of an array of fruit ejector and a collection box. Volume of the

collection box was determined using the following equation 4.

$$\text{Volume of the collection box} = l \times b \times h \quad (4)$$

where, Length, $l = 500$ mm; Breadth, $b = 300$ mm; Height, $h = 300$ mm

$$\begin{aligned} V &= 500 \times 300 \times 300 \\ &= 0.045 \text{ m}^3 \end{aligned}$$

The density of neem fruits in an average is 360 kg.m^{-3} [14]. Hence, the storage capacity of the collection box can be measured using the equation 5.

$$\text{Storage capacity} = \text{Volume of the collection box} \times \text{Density of neem fruits} \quad (5)$$

$$\begin{aligned} &= 0.045 \text{ m}^3 \times 360 \text{ kg.m}^{-3} \\ &= 16.20 \text{ kg} \approx 16 \text{ kg} \end{aligned}$$

Based on the design requirements, collection box of size $500 \times 300 \times 300$ mm with the volume of 16 kg was selected.

2.3.3 Connector frame

Connector frame is a structural element that connects the picker and collector assemblies together.

2.3.4 Traction wheels

The diameter of the traction wheel was designed based on the diameter of picker roller. For rigid traction wheels of diameter 685 mm, the optimum values of lug height, lug angle, rim width and lug spacing were found to be 350 mm, 20° , 200 mm and 110 mm respectively [16].

2.3.5 Handle

The handle was ergonomically designed to accommodate agricultural workers of varying heights, both male and female, so that each individual could adjust them to suit their own height and lessen effort. The average elbow height of women workers while standing is 100 cm. Horizontal distance between the centre of wheel and operator is 115 cm. Therefore, the angle of inclination (θ_h) with the horizontal plane is,

$$\tan \theta_h = \frac{a_1}{a_2} \quad (6)$$

where, a_1 = height of the elbow of the operator from the horizontal line joining the centre of wheel, cm; a_2 = horizontal distance between the

normal to the centre of wheel and normal to the elbow line, cm

$$\begin{aligned} \theta_h &= \tan^{-1} \left(\frac{115}{100} \right) \\ &= \tan^{-1} (1.15) \end{aligned}$$

$$\theta_h = 48.99 \approx 50^\circ$$

Hence, the handle was fastened to the connector frame at an inclination angle of 50° .

2.4 Development of Prototype

The prototype for mechanical type picker collector for neem fruits was developed which essentially consists of the following functional system.

2.4.1 Picking assembly

Picking assembly consists of a picking roller with bristles for the efficient collection of neem fruit from the ground. A 200 mm diameter, poly vinyl chloride hollow pipe closed on both ends using wooden discs was used as picking roller. In the circumference of the roller, 2898 number of holes of 3.5 mm diameter at a spacing of 10×10 mm were drilled and on each holes, flexible round nylon bristles with 55 mm long and 3.5 mm diameter were fixed using strong adhesives. Neem fruits are picked by these bristles when roller rotates in clockwise direction over the ground. The picker roller was attached with the collector assembly using connector frame.

2.4.2 Ejector assembly

Ejector assembly consists of an array of fruit ejecting rods mounted on the rear side of collection box for removing fruits from the roller. The array consists of 45 numbers of 4 mm square ms polished rods of length 200 mm. One end of these rods were mounted on a ms "I" angle with a dimension of $19 \times 19 \times 3.2$ mm whereas other end of these rods freely placed over the roller through the spacing between each row of bristles at an inclination of 50° from the collector. The free end of rods were also slightly bent inwards with a radius of curvature of 100 mm and sharpened at the end so that fruits can easily be removed from the roller and travelled through the space between bristles without affecting the rotation of picker roller.

2.4.3 Collector assembly

Collector assembly used for collection and storage of fruits picked and removed from the roller. The dimension of collection box was $500 \times 300 \times 300$ mm. The frame of the box was made

by 19 x 19 x 3.2 mm MS "L" angle covered with 20 gauge MS sheets on both the sides. The front, rear and bottom of the collection box were closed with a perforated 20 gauge metal sheets with 10 mm aperture size. This perforated metal sheet eliminates the foreign particles such as stones, soil clumps that are smaller than the size of neem fruits.

2.4.4 Connector frame

Connector frame was used to connect the picking and collecting assembly. An 'A' shaped triangular frame was made up of mild steel flat with a dimension of 335 x 305 x 250 mm with a thickness of 3 mm. A mild steel bush having an inner diameter of 25 mm was welded at the apex of the triangular frame through which the roller shaft was mounted.

2.4.5 Traction wheels

A pair of MS rigid lugged wheels of 260 mm diameter and 25 mm width was fabricated and mounded for the mobility of brush roller. Each wheel consists of six number of rim spokes and twelve number of lugs. The lugs were made of mild steel flat with the dimension of 25 x 30 mm. The lugs were welded over the periphery of wheels with a helix angle of 30° to promote the motion of brush roller over the moist soil.

2.4.6 Handle

The push handle was made out of MS round pipe having the length of 450 mm, width of 610 mm and diameter of 25 mm. It was mounted on the connecting frame with the help of 19 mm diameter mild steel (MS) bush. The MS bush was welded at an angle of 60° for providing a better operating posture. The handle was inserted and tightened against the bush using $\frac{5}{16}$ mm x 25 mm length bolt.

2.5 Field Evaluation of the Developed Prototype

The developed prototype of mechanical type neem fruit picker collector was operated in the field for evaluating its performance. Field parameters such as size of the field, soil moisture content and the density of fallen fruits in the field were recorded. The tests were conducted to evaluate the picking efficiency, collection efficiency, collection capacity and field capacity.

2.5.1 Size of the field

A random plot of size 500 x 100 cm in the orchard located at Agricultural Engineering College and Research Institute, Kumulur was taken into consideration and the operation was carried out in the selected plot.

2.5.2 Soil moisture content

The soil moisture content was measured using the oven dry method by collecting soil samples from five random locations of the field. The initial weight of each samples was recorded. These sample were kept in a hot air oven at 80°C. The weight of the sample was monitored once per hour and the experiment continued till the sample attains the same weight for consecutive hours and final weight of the dried sample was noted. Then the average moisture content (wet basis) was calculated.

2.5.3 Density of the ground fallen fruits

The density of neem fruits on the ground were measured by counting the number of neem fruits in a unit square meter area at five different locations in the field.

2.5.4 Picking efficiency

Picking efficiency (η_p) can be defined as the number of fruits picked up to the total number of fruits left on the ground. Picking efficiency can be calculated using the following expression 7 [9].

$$\text{Picking efficiency, } \eta_p = \frac{N_T - N_p}{N_T} \times 100 \% \quad (7)$$

where, N_T = Total number of the fruits on the ground; N_p = Number of fruits picked

2.5.5 Collection efficiency

Collection efficiency (η_c) can be defined as the number of fruit collected in the collection box to the number of fruits retained over the fruit ejection assembly. Collection efficiency can be calculated by the following equation 8. [9]

$$\text{Collection efficiency, } \eta_c = \frac{N_c}{N_r} \times 100 \% \quad (8)$$

where, N_c = Number of fruits collected in the collection box; N_r = Number of fruits retained on the fruit ejection assembly.

2.5.6 Collection capacity

Collection capacity can be defined as the weight of fruit collected in the unit time. It can be determined by the following expression 9 [12].

$$\text{Collection capacity, } C = \frac{W_c}{T} \quad (9)$$

where, W_c = Weight of fruits collected, kg; T = Total time taken for the collection of neem fruits, h.

2.5.7 Field capacity

The field capacity of the prototype was worked out based on the following expression.

$$\text{Field capacity} = \frac{A}{T_p + T_n} \text{ ha.h}^{-1} \quad (10)$$

where, A = Area covered, ha; T_p = Productive time, h; T_n = Non-productive time, h

2.5.8 Cost analysis

In order to determine the financial and economic indicators of the developed prototype, cost economics was calculated. Hence, a simple cost analysis was performed by using annual cost equation 11 [9].

$$AC = FC + \frac{W(VC)}{C} \quad (11)$$

where, AC = Annual cost, Rs.yr⁻¹; FC = Fixed cost, Rs.yr⁻¹; W = Total weight of Neem seed, kg.yr⁻¹; VC = Variable cost, Rs.h⁻¹; C = Collecting capacity, kg.h⁻¹

3. RESULTS AND DISCUSSION

3.1 Properties of Neem Fruit

The pertinent physical properties of neem fruits for the development of mechanical type picker cum collector were studied and measured in Farm machinery Workshop at Agricultural Engineering College and Research Institute, Kumulur. The results obtained are tabulated in Table 1.

3.2 Mechanical Type Neem Fruit Picker Cum Collector

A simple prototype of manually operated mechanical type neem fruit picker collector was developed for the collection of neem fruits from the ground (Fig. 5). The operational view of the mechanical type neem fruit picker collector is shown in Fig. 6. The specification of the developed prototype is furnished in the Table 2.

Table 1. Physical properties of neem fruit

S. No.	Properties	Mean Value	Standard deviation
1.	Moisture content, w.b.,%	81.95	± 0.16
2.	Length, mm	15.57	± 1.20
3.	Width, mm	9.25	± 0.84
4.	Thickness, mm	8.87	± 0.98
5.	Geometric mean diameter, mm	14.07	± 1.47
6.	Thousand- unit mass, g	290.88	± 15.34
7.	Bulk density, g.cm ⁻³	352.00	± 15.90



Fig. 5. Mechanical type neem fruit picker collector



Fig. 6. Operation of neem fruit collection using the developed prototype

Table 2. Physical properties of neem fruit

S. No.	Major components	Specifications
1.	Overall dimensions	1000 x 720 x 1010 mm
2.	Weight	25.80 kg
3.	Picking assembly	
	i. Picking roller	
	Material	Poly Vinyl Chloride (PVC) pipe
	Length of the roller	460 mm
	Diameter of the roller	200 mm
	ii. Bristle	
	Material	Monofilament Nylon wire
	Diameter	3.5 mm
	Length of the bristle	50 mm
4.	Ejector assembly	
	No. of square rod	45
	Material of square rod	Mild steel
	Size of square rod	40 mm
	Length of square rod	200 mm
5.	Collector assembly	
	Material	Mild steel
	Overall dimension(L x W x H)	500 x 300 x 300 mm
	Aperture size	10 mm
6.	Connector frame	
	Material	Mild steel
	Shape	Triangular
	Overall dimension	335 x 300 x 250 mm
	Length of the MS bush	35 mm
	Outer diameter of the MSbush	35 mm
	Inner diameter of the MS bush	20 mm
7.	Handle	
	Material	Mild steel pipe
	Overall dimension (Length x Diameter)	3500 x 25 mm
	Weight	2.0 kg
8.	Traction Wheel	
	Type	Rigid lugged wheel
	Material	Mild steel
	Dimension (Diameter x Width)	260 x 25 mm
	Height of the lugs	30 mm

Table 3. Results of the performance evaluation of mechanical type neem fruit picker collector

S. No.	Particulars	Results
1.	Field condition	
a.	Location	Agricultural Engineering College and Research Institute, Kumulur, Trichy
b.	Coordinates of the field (Latitude and longitude)	10.93175 °N, 78.83256 °E
c.	Plot size, cm	500 x 100
d.	Type of soil	Red loam soil
e.	Soil moisture content, %	8.6
2.	Condition of the operator	
a.	Skill of the operator	Good
b.	Operating speed	1.5 km.h ⁻¹
3.	Field Performance of the prototype	
a.	Time of operation, s	8.54
b.	Unproductive time, s	3
c.	Effective width of operation, cm	50 cm
d.	Field capacity, ha.h ⁻¹	0.15
e.	Collection capacity, kg.h ⁻¹	48
f.	Picking efficiency, %	88
g.	Collection efficiency, %	94

3.3 Performance Evaluation of the Developed Prototype

The performance evaluation of prototype mechanical type neem fruit picker collector in the field evaluation is furnished in Table 3.

3.4 Cost Analysis

The operating cost of the developed unit was calculated by straight line method. The prototype

is assumed to be utilized for 400 h per annum at eight hours of operation per day [9]. The total cost of the developed prototype was Rs. 3500. The fixed cost of the prototype was Rs.2.30 h⁻¹ and Rs.928 per year. The variable cost of the prototype was Rs.63.30 h⁻¹ and Rs.25, 350 per year. The comparison of collection capacity and the cost of collecting neem fruits between three different methods of collection are represented in Fig. 7(a) and Fig. 7(b) respectively.

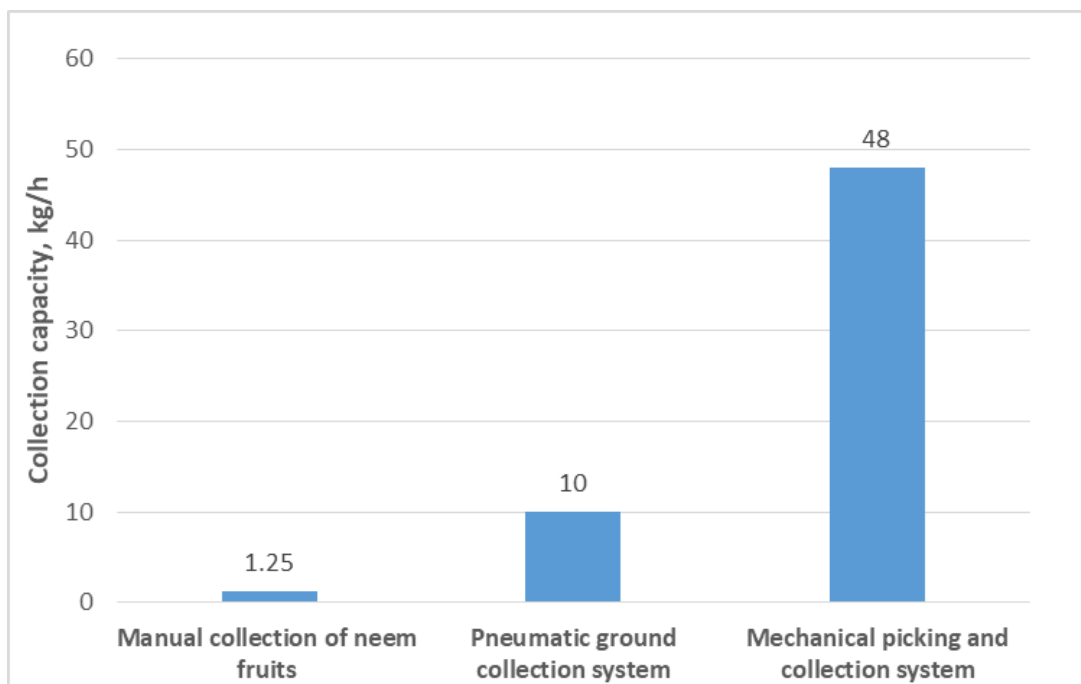

Fig. 7(a). Comparison of the collection capacity of the prototype

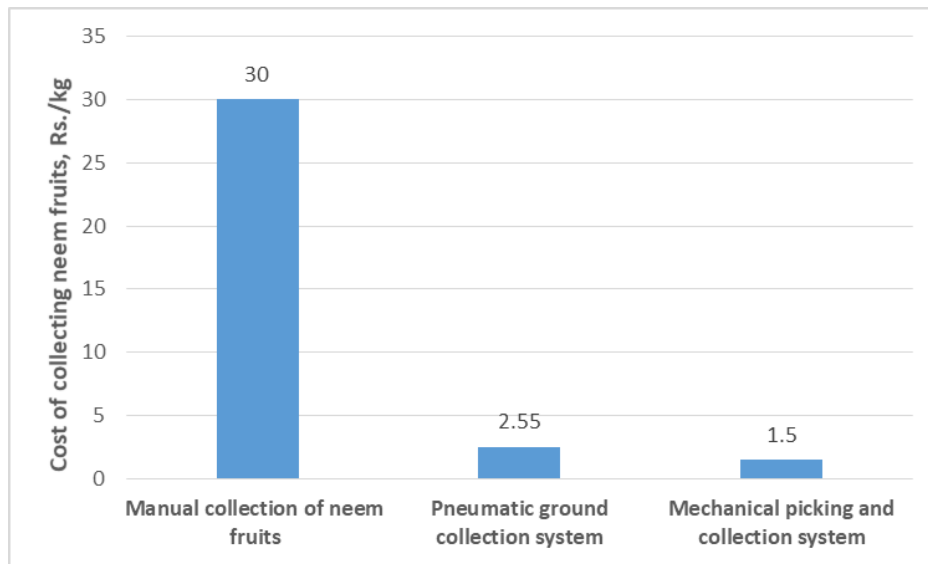

Fig. 7(b). Comparison of the cost of collection of neem fruits

The collection capacity of the mechanical type neem fruit picker collector was 48 kg h^{-1} , whereas collection of capacity of neem from conventional manual method and pneumatic ground collection system was 1.25 kg h^{-1} and 10 kg h^{-1} respectively which is 97 per cent and 79 per cent more than conventional manual method and pneumatic ground collection system respectively. The cost of neem fruit collection using the developed prototype was Rs. 1.5 per kg. The cost of neem fruit collection with conventional method of manual ground collection and pneumatic ground collection system was Rs.30 kg^{-1} and Rs.2.55 kg^{-1} [9]. The developed prototype mechanical type picker collector resulted in 95 per cent and 41.18 per cent saving in cost when compared with conventional method of collection pneumatic type ground collection system respectively. The break-even point of the developed prototype was 1180 kg.yr^{-1} . The time needed to recover the cost of the unit was 0.25 years.

4. CONCLUSION

The development of the mechanical type neem fruit picker collector is a significant advancement in the neem fruit harvesting process. This study was carried out to develop and evaluate the mechanical type neem fruit picker collector. The developed unit of mechanical type neem fruit picker collector had the major components viz. Picker assembly, Ejector assembly, collector assembly, connector frame, handle and traction wheel. The collection capacity of the developed machine (48 kg.hr^{-1}) shows 97.3% saving in time

and 95% saving in cost when compared with conventional method of collection and 79 % saving in time and 41% saving in cost when compared with existing pneumatic type ground collection system. The developed unit entailed an investment cost of Rs. 3500. The payback period of the developed unit was estimated as 3 months. This machine has the potential to revolutionize the way that neem fruits are harvested, and to make neem fruit harvesting more efficient, productive, and cost-effective. In future, arrangements may be made to attach the developed prototype with mini-tractor for operating in large neem plantations.

COMPETING INTERESTS

Authors have declared that no competing interests exist.

REFERENCES

1. Ahmed S, Grainge M. Potential of the neem tree (*Azadirachta indica*) for pest control and rural development. *Economic Botany*. 1986;40(2):201–209. Available:<https://doi.org/10.1007/BF02859144>
2. Karmakar A, Karmakar S, Mukherjee S. Biodiesel production from neem towards feedstock diversification: Indian perspective. *Renewable and Sustainable Energy Reviews*. 2012;16(1): 1050–1060. Available:<https://doi.org/10.1016/j.rser.2011.10.001>
3. Masilamani P, Albert VA, Selvam S, Kumaran K. Effect of different methods of

- depulping on viability, germination, seedling vigour and its economic analysis in neem (*Azadirachta indica* A. Juss.). Range Management and Agroforestry. 2023;44(01):95–101.
Available:<https://doi.org/10.59515/rma.2023.v44.i1.11>
4. Bandyopadhyay U, Biswas K, Sengupta A, Moitra P, Dutta P, Sarkar D, Debnath P, Ganguly C. K, Banerjee RK. Clinical studies on the effect of Neem (*Azadirachta indica*) bark extract on gastric secretion and gastroduodenal ulcer. Life Sciences. 2004;75(24):2867–2878.
Available:<https://doi.org/10.1016/j.lfs.2004.04.050>
 5. Chhabra M, Saini BS, Dwivedi G. Impact assessment of biofuel from waste neem oil. Energy Sources, Part A: Recovery, Utilization and Environmental Effects. 2021;43(24):3381–3392.
Available:<https://doi.org/10.1080/15567036.2019.1623946>
 6. Kumar VS, Navaratnam V. Neem (*Azadirachta indica*): Prehistory to contemporary medicinal uses to humankind. Asian Pacific Journal of Tropical Biomedicine. 2013;3(7): 505–514.
Available:[https://doi.org/10.1016/S2221-1691\(13\)60105-7](https://doi.org/10.1016/S2221-1691(13)60105-7)
 7. Kumar S, Singh N, Devi LS, Kumar S, Kamle M, Kumar P, Mukherjee A. Neem oil and its nanoemulsion in sustainable food preservation and packaging: Current status and future prospects. Journal of Agriculture and Food Research. 2022;7:100254.
Available:<https://doi.org/10.1016/j.jafr.2021.100254>
 8. Ogbuewu IP, Odoemenam YU, Obikaonu HO, Opara MN, Emenalom OO, Uchegbu MC, Okoli IC, Esonu BO, Iloeje MU. The growing importance of neem (*Azadirachta indica* A. Juss) in agriculture, industry, medicine and environment: A review. Research Journal of Medicinal Plant. 2011;5(3):230–245.
Available:<https://doi.org/10.3923/rjmp.2011.230.245>
 9. Tripathi AV, Suthakar B, Surendrakumar A, Kavitha R, Raja K. Design and development of ground collection system for neem fruit. International Journal of Environment and Climate Change. 2022;12(11):2095–2104.
Available:<https://doi.org/10.9734/ijecc/2022/v12i1131199>
 10. Lokanadhan S, Muthukrishnan P, Jeyaraman S. Neem products and their agricultural applications. Journal of Biopesticides. 2012;5(SUPPL.): 72–76.
 11. Solanki RC, Santosh S, Singh SP, Naik SN, Srivastava, A. P. Design, development and evaluation of neem depulper. AMA, Agricultural Mechanization in Asia, Africa and Latin America. 2017;48(4): 45–51.
 12. Ismail MA. Bin. (n.d.). Design and development of coconut palm collector.
 13. Adedeji MA, Sanni OS, Adesanya IK, Adesina AOC. Determination of Physical and Mechanical properties of neem (*Azadirachta indica* A.Juss) fruits that enhances depulping. International Journal of Engineering and Technology Research Published by Cambridge Research and Publications. 2021; 21(5):179–194.
 14. Balami AA, Aliyu M, Dauda SM, Peter O. Physical properties of neem (*Azadirachta indica*) seeds and kernels relevant in. Arid Zone. Journal of Engineering, Technology and Environment. 2014;10(2009):53–62.
 15. Kishore SG, Rajkumar P, Sudha P, Deepa J, Subramanian P, Kennedy ZJ. Engineering properties of neem (*Azadirachta indica*) fruit and seed for the development of depulper and decorticator. Emergent Life Sciences Research. 2022;08(01):207–223.
Available:<https://doi.org/10.31783/elsr.2022.81207223>
 16. Pandey KP, Ojha TP. Effect of design parameters on the performance of rigid traction wheels on saturated soils. Journal of Terramechanics. 1978;15(3):145–156.
Available:[https://doi.org/10.1016/0022-4898\(78\)90017-4](https://doi.org/10.1016/0022-4898(78)90017-4)

© 2024 Gowtham et al.; This is an Open Access article distributed under the terms of the Creative Commons Attribution License (<http://creativecommons.org/licenses/by/4.0>), which permits unrestricted use, distribution, and reproduction in any medium, provided the original work is properly cited.

Peer-review history:

The peer review history for this paper can be accessed here:
<https://www.sdiarticle5.com/review-history/112842>